

TargetLink Connects to AUTOSAR

- **Model-based designing for AUTOSAR ECUs**
- **Generating AUTOSAR-compliant code**
- **Software component descriptions generated automatically**

The AUTOSAR initiative is without doubt one of the automotive industry’s most forward-looking and important undertakings. TargetLink 2.2 therefore includes a TargetLink AUTOSAR blockset for generating code for AUTOSAR software components. These contain the actual function code for an electronic control unit (ECU), which is TargetLink’s natural domain. As always, TargetLink 2.2 not only generates code for AUTOSAR software components, but also gives extensive support for modeling and simulating them.

AUTOSAR-Compliant ECU Software Development with TargetLink 2.2

In the AUTOSAR software architecture, function code is encapsulated in AUTOSAR software components (SW-Cs), which communicate with one another and with services in the AUTOSAR basic software exclusively via well defined, standardized interfaces. These interfaces are made available by the run-time environment (RTE). Function code that meets these requirements can be generated via an optional AUTOSAR module for TargetLink 2.2, which supports modeling and code generation for SW-Cs.

Modeling and Simulating AUTOSAR Software Components

For users who need to model SW-Cs, TargetLink 2.2 provides special TargetLink AUTOSAR blocks for specifying AUTOSAR’s structural elements, such as runnable entities, ports, etc. This combination of TargetLink AUTOSAR blocks and the proven TargetLink blockset gives developers an easy-to-use and extremely powerful modeling tool for implementing controller models in AUTOSAR-compliant components. All the specifications required for the SW-Cs are made in the familiar TargetLink/Simulink® environment, which makes the modeling of AUTOSAR software components particularly attractive and efficient. TargetLink also supports the simulation of SW-Cs in the MIL/SIL/PIL simulation modes, though not every AUTOSAR communication mechanism can be simulated completely realistically in Simulink.

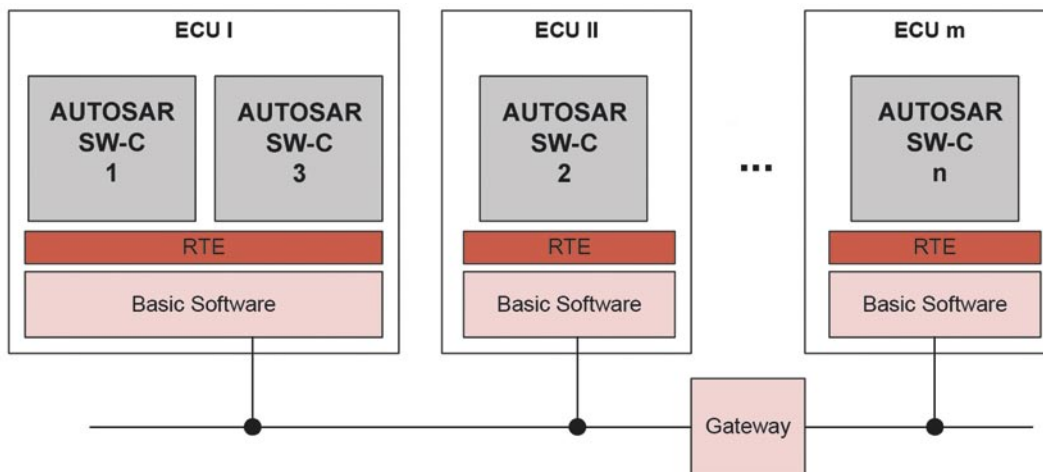

▲ TargetLink 2.2 generates code for AUTOSAR software components (SW-C) as an application-specific part of the AUTOSAR software architecture.

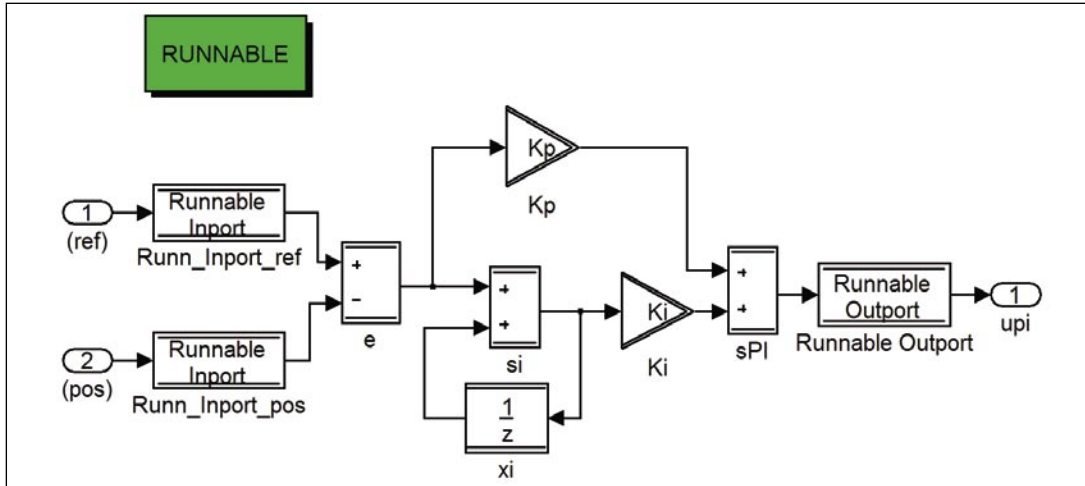

◀ AUTOSAR software components are modeled by means of the additional TargetLink AUTOSAR blockset. Shown here are the blocks for runnables and AUTOSAR inports/outputs.

Code Generation for AUTOSAR Software Components

When the specification has been completed at block level and in the dSPACE Data Dictionary, actually generating AUTOSAR-compliant code takes only a few clicks. Since communication with each software component runs exclusively via the RTE, the code generated by TargetLink contains the RTE macros needed for data exchange. TargetLink supports various AUTOSAR communication mechanisms, such as sender/receiver communication and client/server communication.

In addition to generating the actual C code, TargetLink 2.2 also provides a standardized description of the AUTOSAR software components in XML format. This description is needed for tool-supported integration of the code, as it contains information on structure elements such as runnable entities, ports, etc.

Generating AUTOSAR software components with TargetLink provides all the usual advantages of model-based design.

These are some of the other new features in TargetLink 2.2, in addition to AUTOSAR software component generation:

- **Function interfaces with pointers to structures:**
TargetLink 2.2 now also supports pointers to structures in the function signature, which is particularly efficient where there are a large number of function parameters and which improves the structuring of the generated code.
- **TOM and TSM extensions:**
New modules for TargetLink 2.2 include processor-optimized code generation (TOM) for MPC55xx/Diab and target simulation (TSM) for TC1766/Tasking and S12X/Metrowerks.
- **More flexible code generation:**
TargetLink's numerous code generation options have been extended, for example, with regard to variant coding, and by access functions for structures and bitfields. Further Code Generator settings can be made in a convenient user interface.
- **Extended modeling options:**
TargetLink 2.2 not only allows numerous blocks to inherit properties, it also supports bus-capable blocks and nested graphical functions.
- **Multi-edit functionality in the Data Dictionary Manager:**
The properties of multiple data dictionary objects such as variables can now be modified simultaneously, which greatly simplifies the handling of large data volumes with the Data Dictionary Manager.
- **Requirements Management Interface:**
TargetLink 2.2 simplifies connection to the Requirements Management Interface of the Simulink Verification & Validation Toolbox to link TargetLink blocks with requirements.